

Dual Power Automatic Transfer Switch

RDQ3NM Series

Working Mode

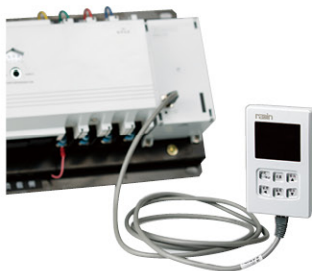

- RDQ3NM series intelligent dual power ATS have two working mode: Auto mode and Manual mode.
- Auto Mode: RDQ3NM series ATS according to the controller functions have three modes: Auto change Auto recovery (R) Auto change no auto recovery (S) and Power Grid-Generator (F), the first two mode used in power grid-power grid system, the latter mode is used in power grid-generator system.
- Manual mode: manual mode has three working mode, main power, backup power and breaker trip modes. Under manual working mode, there will be no auto transfer function.
 - Main power mode: Forced disconnecting backup power, and turn ON the main power;
 - Backup power mode: Forced disconnecting the main power and turn ON the backup power;
 - Breaker trip mode: To disconnecting two power sources, also can switch on the fault tripped circuit breaker.

Outline And Installation Dimensions(mm)

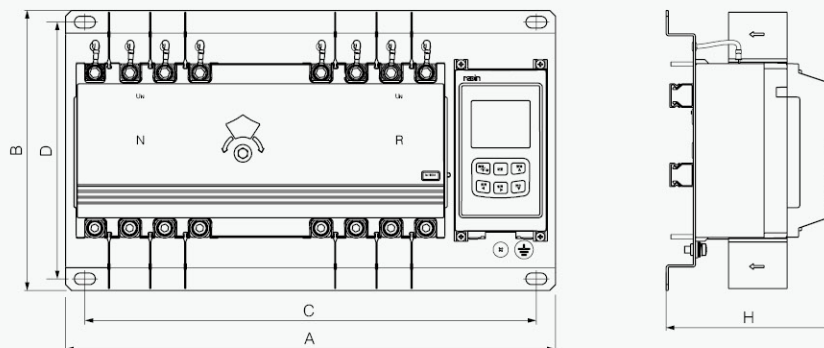

Note: The 4pcs mounting screw is M8 size.

Type	Size	A		B	C		D	H
		3P	4P		3P	4P		
RDQ3NMB-63		355	380	240	322	348	220	145
RDQ3NMB-100		390	420	240	358	388	220	145
RDQ3NMB-225		435	470	240	402	438	220	145
RDQ3NMB-400		565	615	330	505	555	300	200
RDQ3NMB-630		682	740	330	622	680	300	200
RDQ3NMB-800		720	790	350	665	735	320	200
RDQ3NMB-1250		730	800	390	685	755	367	252

RDQ3NM Series

Terminal Wiring

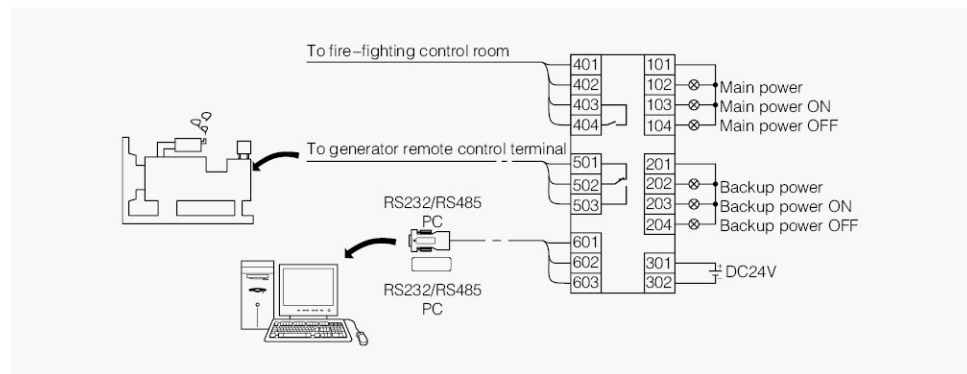

Controller Features And Functions

- This product adopt B type controller;
- Can set the controller working mode and transfer data by the control button;
- Through the display can directly read the measuring and control data, including the voltage and delay time etc.
- Fire linkage control function: controller with a set of passive fire-fighting signal input terminal. The input signal using opto-coupler isolation, have strong anti-interference ability; And also have a set of passive feedback signal output terminals, can send the switching position back to fire-fighting control equipment.
- Generator start/stop control function: Controller with a relay contact point to control the generator start and stop, and also can manually setting the generator start/stop delay time (need connect a aux. power with DC15-30V);
- Can remove the display panel and install on the switchgear panel, users can observe the ATS status without open the switchgear doors.

Split Controller Outline And Mounting Size(mm)

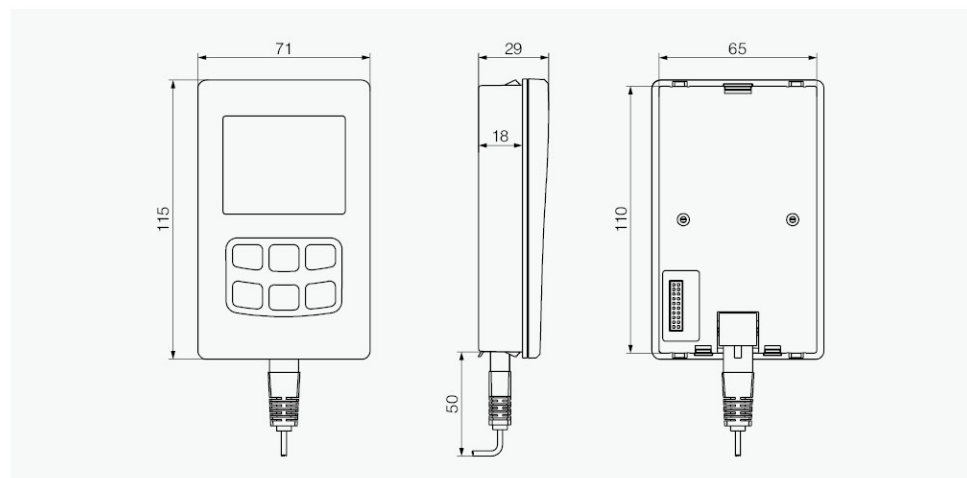

Dual Power Automatic Transfer Switch

RDQ3NM Series

Terminal Wiring Instruction

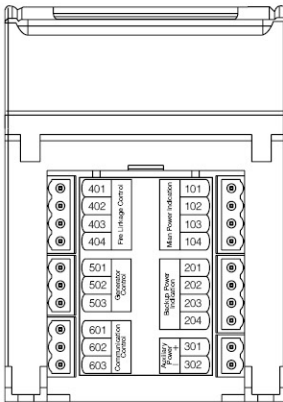

- 101~104 Main power external indicator signal (Active AC220V/0.5A)
 101-Indicator common null line 102-Main power indicator signal output
 103-Main power ON signal output 104-Main power trip signal output
- 201~204 Backup power external indicator signal (Active AC220V/0.5A)
 201-Indicator common null line 202-Backup power indicator signal output
 203-Backup power ON signal output 204-Backup power trip signal output
- 301~302 Controller DC aux. power input (DC15V~30V/0.5A)

The main purpose to put an aux. power is to control the generator start delay time under the Power grid-Generator mode, if without aux. power, the generator start delay time is 0s, if the generator start delay function not needed, then no need to connect the aux. power .

- 401~404 Fire linkage control terminal; Used to remote control cutoff the ATS power supply after the fire alarm.

401, 402 Fire linkage control signal input terminal, this terminal external only connect to a set of NO passive contact point(if the signal from fire-fighting equipment is an active signal, must first pass through a small relay, then connect the relay NO point to controller, otherwise will burn the controller), when the external contact point closed, the controller immediately control the switch transfer to OFF position to switch off the load power supply, at same time through 403 and 404 terminal to send the signal back to fire-fighting control center;

403, 404 Inside is a set of NO relay contact point, used for sending the fire-fighting movement signal back; when it is normal, the contact is NO status, when there is fire-fighting signal input to the controller, and the switch transfer to OFF position, the 403 and 404 closed. (Notes: when the fire linkage function is active, the ATS will stop working, if want the ATS to working again, must first clear up the fire-fighting signal and then switching the Auto/Manual control switch one time, the ATS will recovery normal working)

- 501~503 Generator start control output terminals

When the backup power is Auto start generator, users can connecting the 501~503 terminals to the generator controller to achieve the generator auto start function, inside 501~503 terminal, there is a 3A passive relay contact point, 502 is the relay common terminal, 503 is relay NC point, 501 is relay NO point; Under Power grid-Generator mode and controller is auto mode, when main power normal, 502 and 501 is closed, 502 and 503 open, if main power failure and backup power no electricity, 502 and 503 closed after generator start delay time, and meanwhile 502 and 501 open to send the generator start signal, after generator start successfully, it auto transfer to the backup power supply, during the backup power supply normally and if main power recovery, then after the recovery delay time control, it transfer to main power supply, main power circuit breaker ON, then after generator stop delay time 502 and 501 closed, 502 and 503 open to send generator stop signal.

RDQ3NM Series

Controller Panel Functions

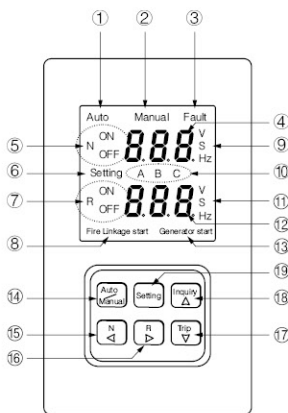

- 1.Auto mode indication;
- 2.Manual mode indication;
- 3.Fault indication: When ATS is fault or load short circuit causes the circuit breaker trip, this indicator will lighten;
- 4.Main power voltage data indication zone : under working status, it display the main power voltage and time delay, under setting status, it display the item code;
- 5.Main power circuit breaker ON/OFF indicate;
- 6.Setting status indicate;
- 7.Backup Power circuit breaker ON/OFF indicate;
- 8.Fire linkage function start indicate;
- 9.Main power voltage, time and frequency unit;
- 10.A, B, C phase indicate;
- 11.Backup power voltage, time and frequency unit;
- 12.Backup power voltage data indication zone :
under working status, it display the backup power voltage and time delay, under setting status, it display the item code;
- 13.Generator start signal indicate;
- 14.Auto/Manual mode select button:
under working status it used to select the Auto and Manual mode, under the setting status it used as save and escape function;
- 15.Main power transfer button:
under manual control mode and main power good, push this button will forced to transfer to main power; Under setting status, it used for up page button;
- 16.Backup power transfer button:
under manual control mode and backup power good, push this button will forced to transfer to backup power; Under setting status, it used for down page button;
- 17.Trip button:
under manual control mode if any one of the two power is good, push this button will change to OFF position; under setting status it is used for data reduce button;
- 18.Fault inquiry button:
if the fault indicator is lighten on the display, through this button can check the fault code; under setting status it is used for data increase button;
- 19.Setting button:
push this button will enter into the controller setting menu.