

Intelligent Frame Type Universal Breaker

RDW1(DW45) Seriesv

General



RDW1 Series circuit breaker is mainly used in rated service current up to 6300A of distribution networks to distribute electric energy and protect lines.

- AC rated current: 630-6300A;
- Short-circuit breaking capacity: 80kA-120kA;
- Rated working voltage below AC690V;
- Both the 3 poles and 4 poles are available;
- Two types: Draw-out type and fixed type;
- Equipped with many types of intelligent controllers with different functions;
- Standards: IEC60947-2, GB14048.2.

Model

R DW 1 - □ □
 ↓ ↓ ↓ ↓ ↓
 ① ② ③ ④ ⑤

①	Company code
②	Air circuit breaker
③	Design code
④	Frame class rated current
⑤	number of poles (3 pole may be omitted)

Operation Conditions

- When the ambient air temperature is -5°C to $+40^{\circ}\text{C}$, the mean value is no greater than $+35^{\circ}\text{C}$ within 24 hours.
- Altitude: not higher than 2000m for the installation site.
- When the ambient air temperature is $+40^{\circ}\text{C}$, the relative humidity of the air shall not be higher than 50%; a higher relative humidity is allowed at a lower temperature; for example, for the wettest month, the maximum relative humidity averaged shall be 90% while the lowest temperature averaged in that month $+20^{\circ}\text{C}$, and special measures shall be taken for the condensation occasionally produced due to temperature change.
- Pollution grade: Class 3.
- The installation category of the breaker's main circuit is IV and the control circuit and auxiliary circuit being III.
- The circuit breaker should be installed according to the manual. The vertical tilt angle should not exceed 5° .
- If the air circuit breaker is installed in a small compartment of the switch board, the protection grade is up to IP40.

RDW1(DW45) Seriesv

Feature



- a. Intelligent controller types: H type (communication type), M type (standard type), L type (economic type), 2M type (high immunity type) and 2H type (high immunity communication type);
- b. It has overload long time-delay, short circuit short time-delay and short circuit instantaneous functions;
- c. single-phase earthing fault protection;
- d. Display function: setting current display, action current display and each phase voltage display (the voltage display should be informed when ordering);
- e. Alarm function: overload alarm;
- f. Self checking function: overheat self checking and micro self checking;
- g. Test function: Action characteristics of test controller.

Main Technical Parameters

Rated current table	
Frame class rated current $I_{nm}(A)$	Rated current $I_n(A)$
2000	400, 630, 800, 1000, 1250, 1600, 2000
3200	2000, 2500, 2900, 3200
4000	3200, 3600, 4000
6300	4000, 5000, 6300

Rated short circuit breaking capacity and short time withstand current table					
Frame class rated current		2000	3200	4000	6300
rated ultimate short circuit breaking capacity	400V	65	80	100	120
$I_{cu}(kA)_{o-co}$	690V	50	65	65	85
rated short circuit making capacity	400V	176/0.2	220/0.2	220/0.2	264/0.2
$n \times I_{cu}(kA)/\cos\Phi$	690V	105/0.25	143/0.2	143/0.2	187/0.2
rated operation short circuit breaking capacity	400V	40	50	65	100
$I_{cs}(kA)_{o-co-co}$	690V	40	65	65	75
rated short time withstand current	400V	40	65	65/80(MCR)	85/100(MCR)
(kA)1s 0.4s, o-co	690V	40	50	50/65(MCR)	65/75(MCR)

Intelligent Frame Type Universal Breaker

RDW1(DW45) Seriesv

Main Technical Parameters

The maximum loss power is 360W, and changed current at different temperature							
Ambient Temperature℃	Rated Current						
	400A	630A	800A	1000A	1250A	1600A	2000A
40	400A	630A	800A	1000A	1250A	1600A	2000A
50	400A	630A	800A	1000A	1250A	1550A	1900A
60	400A	630A	800A	1000A	1250A	1550A	1800A

Note: The capacity-reducing factor is 0.9 for above 2500A. The 4000A of 6000A is not reducing capacity.

Controller setting current Ir(I/In)and tolerance table						
long time-delay Ir1	short time-delay		instantaneous		earthing fault	
	Ir2	tolerance	Ir3	tolerance	Ir4	tolerance
(0.4-1)In	(0.4-15)In	±10%	In-50kA(Inm=2000A) In-75kA (Inm=3200A~4000A) In-100kA(Inm=6300A)	±15%	Inm=2000~4000A (0.2~0.8)In (The maximum 1200Athe minimum 160A)	±10%

long time-delay overcurrent protection, inverse time characteristics $I^2T_L=(1.5I_r1)^2T_L$ (1.05~2.0)Ir1action time table, and the time tolerance is ±15%

1.05Ir1	1.3Ir1	1.5Ir1setting time s	15	30	60	120	240	480
>2hNon-trip	<1h Trip	2.0Ir1action time s	8.4	16.9	33.7	67.5	135	270

The short time-delay overcurrent protection characteristics is limited time.If the low multiple is inverse time, the characteristics: $I^2Ts=(8I_r1)^2ts$, tsts is time-delay design time; when the overcurrent>8Ir1, It changes to limit time. The time tolerance is±15%

delay time(s)				Return time(s)			
0.1	0.2	0.3	0.4	0.06	0.14	0.23	0.35

RDW1(DW45) Seriesv

Product Structure



Intelligent Frame Type Universal Breaker

RDW1(DW45) Seriesv

Connection Terminals

Circuit breaker have total 47 terminals.The connection diagram refer to Pic.A, Pic.B and Pic.C.

#1, #2 AC AC working power supply input(Input from DC power module U1 and U2 in AC current)

#25, #26 connect with neutral pole or input from current transformer.

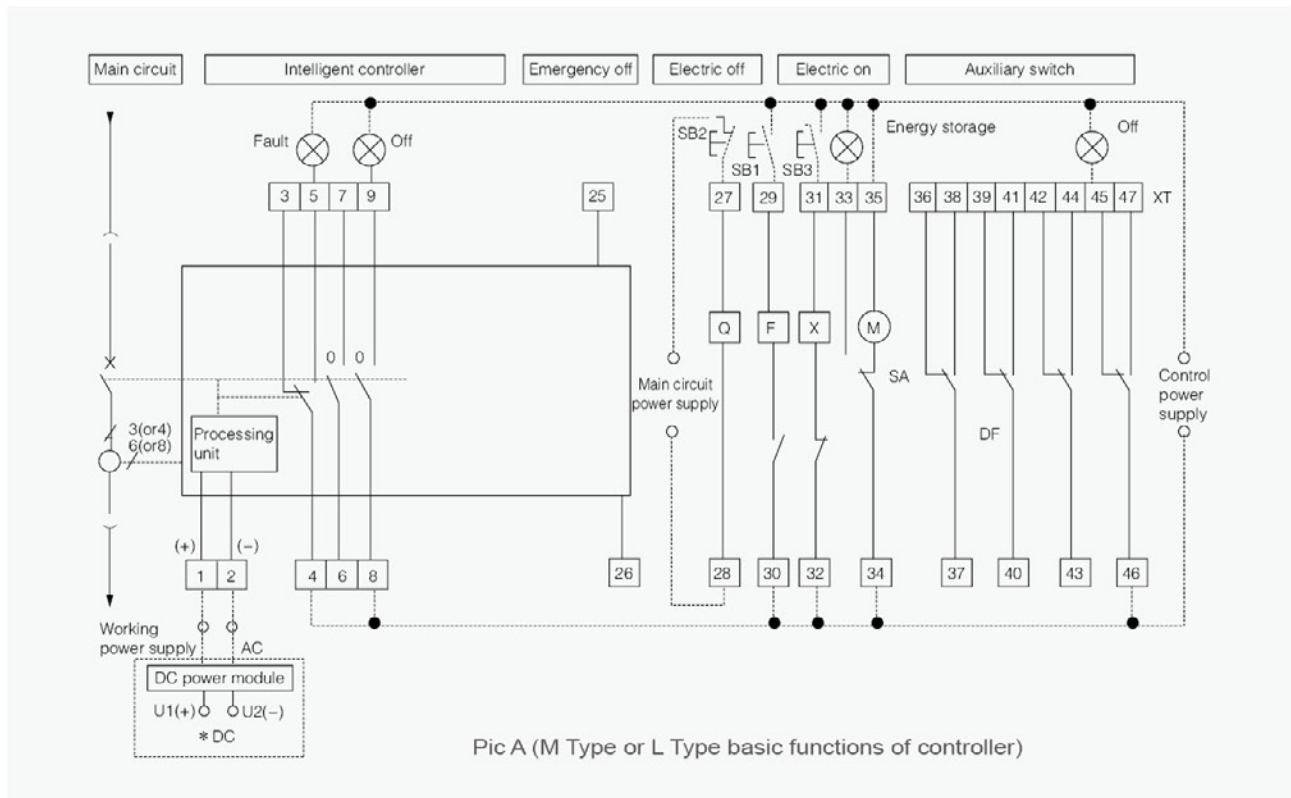

Note:

- If the F, X, M voltage of control power is different, it need connect with different power supply.
#35 can be connected with power supply directly(automatic energy storage), also can be connected with NC button firstly, then for power supply (manual energy storage).
- #6-#7 NC contact output (user provide accessories)
- When the controller working power supply is DC current, it need add DC power module.(#1 and #2 terminals cannot be connected with AC power supply).The secondary diagram refer to picture (DC110V or 220V input from U1(+) and U2(-), and two output terminals of DC power module connect with secondary connection terminals 1(+) and 2(-).)

M-energy storage motor	SB1-shunt button	SA-sensitive switch
XT-connection terminal	SB2-under voltage button	Q-under voltage release or under voltage delay release
DF-auxiliary contact	SB3-On button	O-NO contact (3A/AC380V)
F-shunt release	X-closing electromagnet	⊗-Indicator light

RDW1(DW45) Seriesv

- Other connection of intelligent controller
 - #1 #2 AC working power supply input (Input from DC power module U1 and U2 in AC current)
 - #12 overload alarm
 - #14 Instantaneous short time-delay output
 - #15 long time-delay output
 - #16 earthing fault output
 - #19 public line output
 - #20 self-checking output
 - #21 tripping output
 - #25, #26 connect with neutral pole or input from current transformer

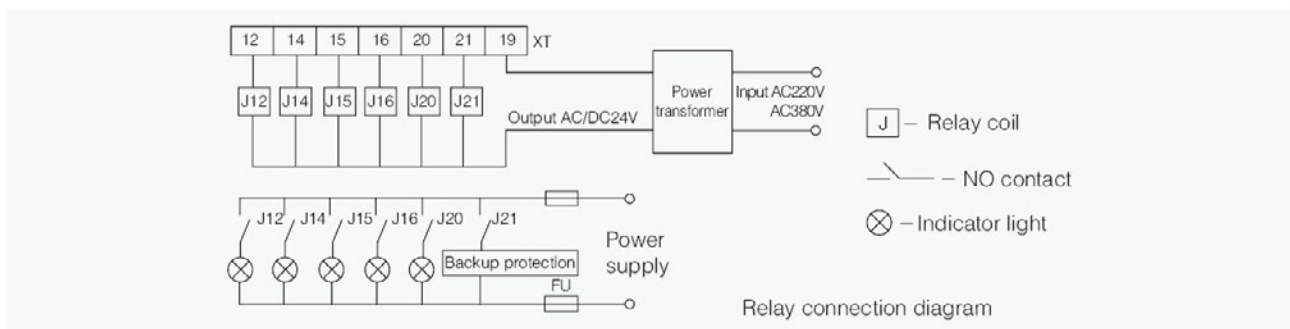

- 1)The controller output drives relay J according terminal 12, 14-16, 20 and 21 to operate.
- 2)Power transformer is supplied by manufacturer.The power transformer and relay base are inserted in the Din rail, then installed in the switchgear.
- 3)Relay type: HH62P
- 4)The conditions of self-checking output: a. controller inside temperature > 80°C; b.chip abnormally works; c. the controller losses power.
- 5)User can choose J12, J14-J16, J20 and J21.

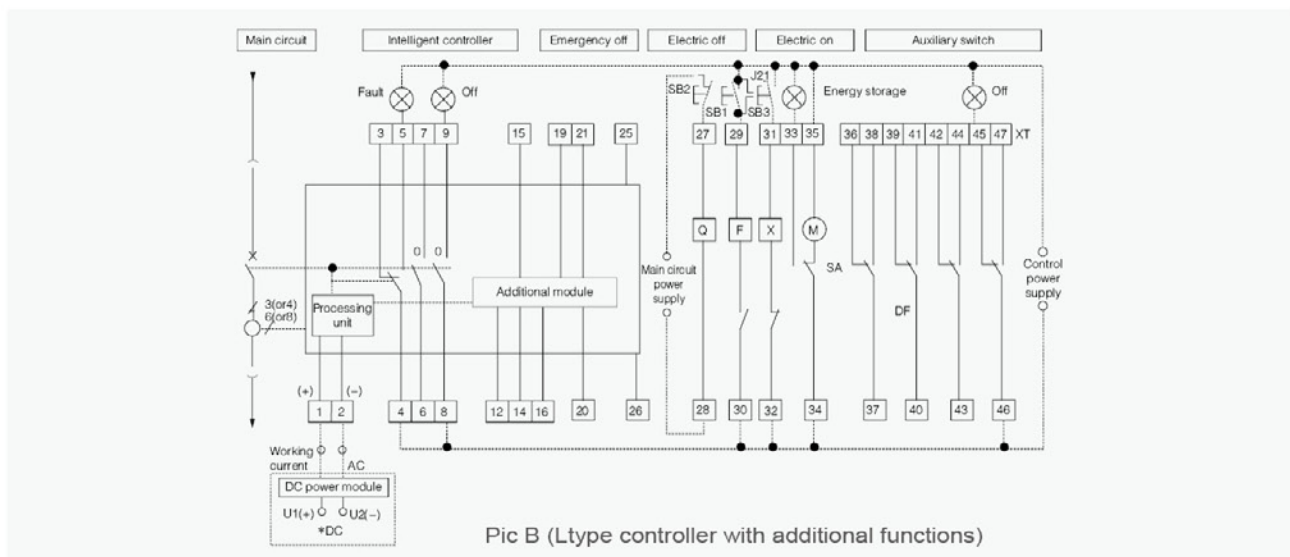

Intelligent Frame Type Universal Breaker

RDW1(DW45) Seriesv

Note:

- If the F, X, M voltage of control power is different, it need connect with different power supply.
- #35 can be connected with power supply directly(automatic energy storage), also can be connected with NC button firstly, then for power supply (manual energy storage).
- #6-#7 NC contact output (user provide accessories)
- User provide additional accessories.
- When the controller working power supply is DC current, it need add DC power module.(#1 and #2 terminals cannot be connected with AC power supply).The secondary diagram refer to picture (DC110V or 220V input from U1(+) and U2(-), and two output terminals of DC power module connect with secondary connection terminals 1(+) and 2(-).)

SB1-shunt button

M-energy storage motor

SA-sensitive switch

SB2-under voltage button

XT-connection terminal

Q-under voltage release or under voltage delay release

SB3-On button

DF-auxiliary contact

O-NO contact (3A/AC380V)

X-closing electromagnet

F-shunt release

⊗-Indicator light

Other connection of intelligent controller

#1#2 AC working power supply input (Input from DC power module U1 and U2 in AC current)

#17 Unload load 1 output

#10 RS485 Communication P terminal

#18 Unload load 2 output

#11 RS485 Communication N terminal

#19 public line output

#12 overload alarm output

#20 Self-checking output

#13 shunt tripping output

#21 tripping output

#14 Instantaneous short time-delay output or communication remote switch output

#22 Voltage A phase

#15 long time-delay output or communication remote energy storage output

#23 Voltage B phase

#16 earthing fault output

#24 Voltage C phase

#25, #26 connect with neutral pole or input from current transformer.

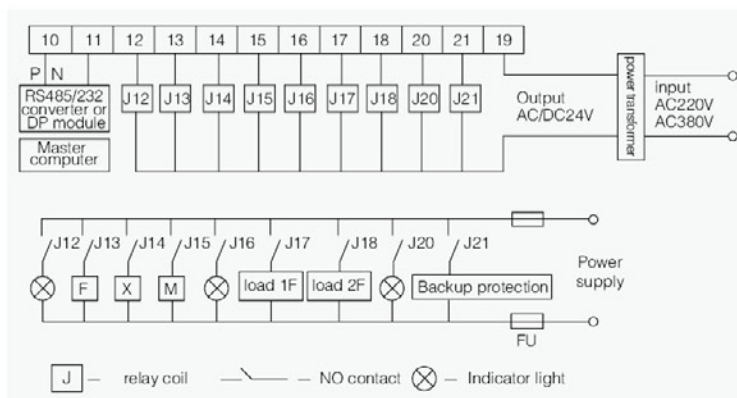

1)The controller output drives relay J according terminal 12-18, , 20 and 21 to operate.

2)RS485/232 converter, DP module and power transformer is supplied by manufacturer.The power transformer and relay base are inserted in the Din rail, then installed in the switchgear.

3)Relay type: HH62P, AC/DC24V

4)User provide master computer1

5)The terminal #13-#15 output can provide communication remote control switch on, off and energy storage, and the terminal #14 and #15 are not tripping output.The relay NO contact parallel connect with manual button.If it not need remote

function, the terminal #14 and #15 are in series with indicator light according to relay J14 and J15 NO contacts.The terminal #21 output drives relay J21 to be backup protection.

6)The conditions of self-checking output: a. controller inside temperature > 80°C ; b.chip abnormally works; c the controller losses power.

7)User can choose J12, J14-J16, J20 and J21.

RDW1(DW45) Seriesv

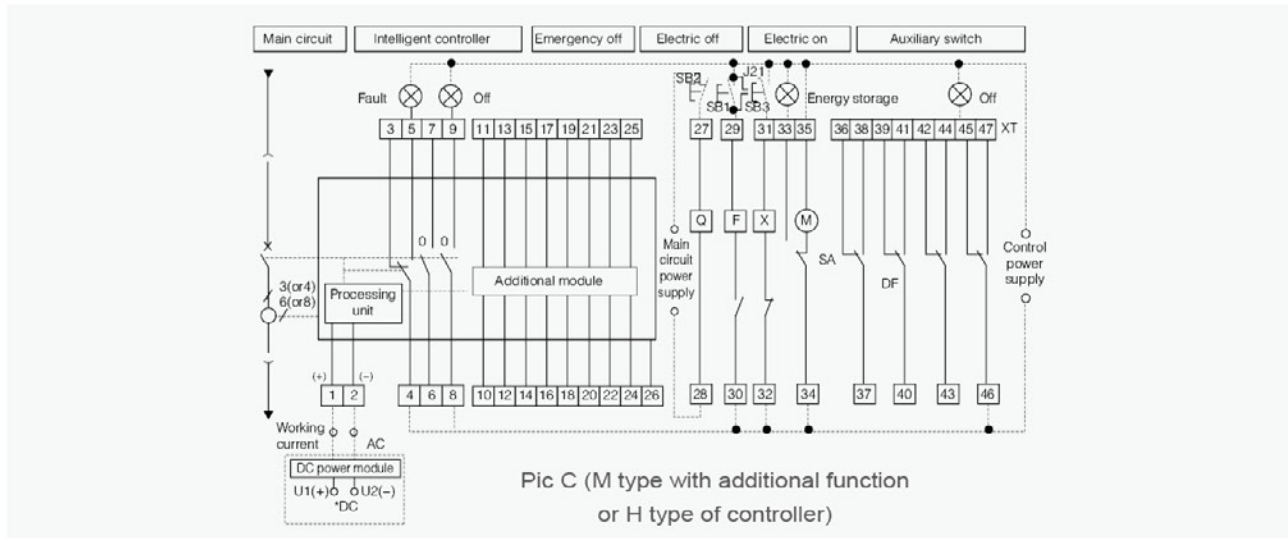

Note:

- If the F, X, M voltage of control power is different, it need connect with different power supply.
- #35 can be connected with power supply directly(automatic energy storage), also can be connected with NC button firstly, then for power supply (manual energy storage).
- #6-#7 NC contact output (user provide accessories)
- User provide additional accessories.

When the controller working power supply is DC current, it need add DC power module.(#1 and #2 terminals cannot be connected with AC power supply).The secondary diagram refer to picture (DC110V or 220V input from U1(+) and U2(-), and two output terminals of DC power module connect with secondary connection terminals 1(+) and 2(-).)

SB1-shunt button

M-energy storage motor

SA-sensitive switch

SB2-under voltage button

XT-connection terminal

Q-under voltage release or under voltage delay release

SB3-On button

DF-auxiliary contact

O-NO contact (3A/AC380V)

X-closing electromagnet

F-shunt release

⊗-Indicator light

Overall And Mounting Dimensions (mm)

- Fixed type circuit breaker mounting and overall dimensions (RDW1-2000, 2000/4)

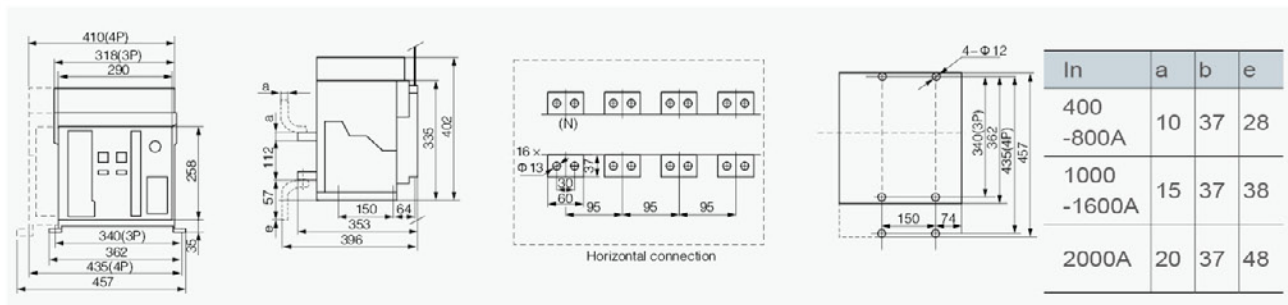

Intelligent Frame Type Universal Breaker

RDW1(DW45) Seriesv

Overall And Mounting Dimensions (mm)

- Fixed type circuit breaker mounting and overall dimensions (RDW1-3200)

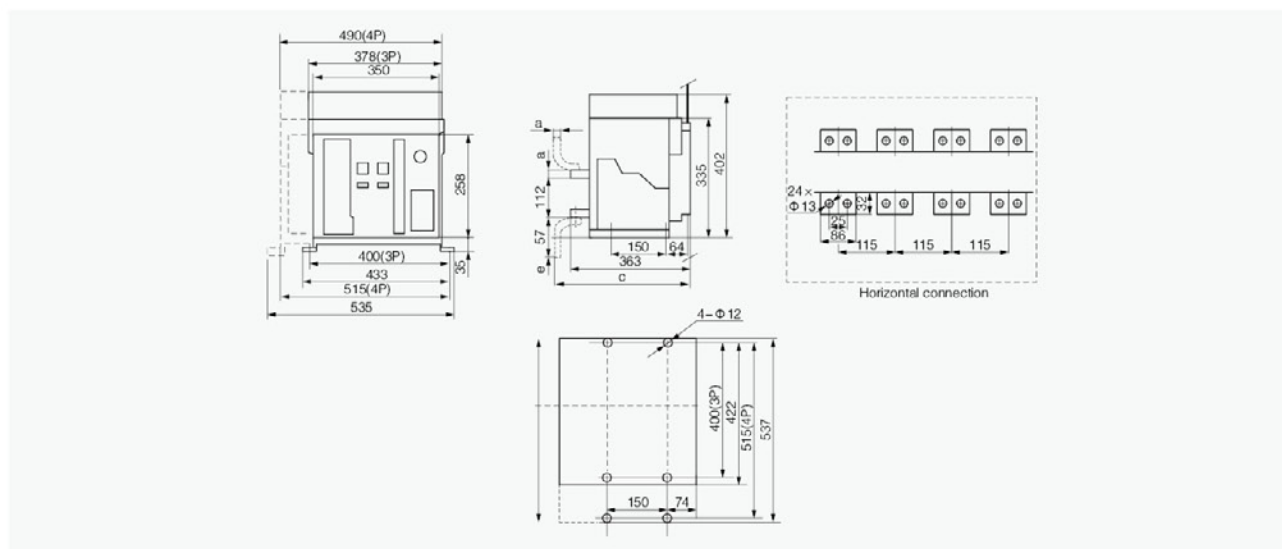

In	a	b	c	e
2000A, 2500A	20	32	408	58
2900A, 3200A	30	32	428	78

- Draw-out circuit breaker mounting and overall dimensions (RDW1-2000)

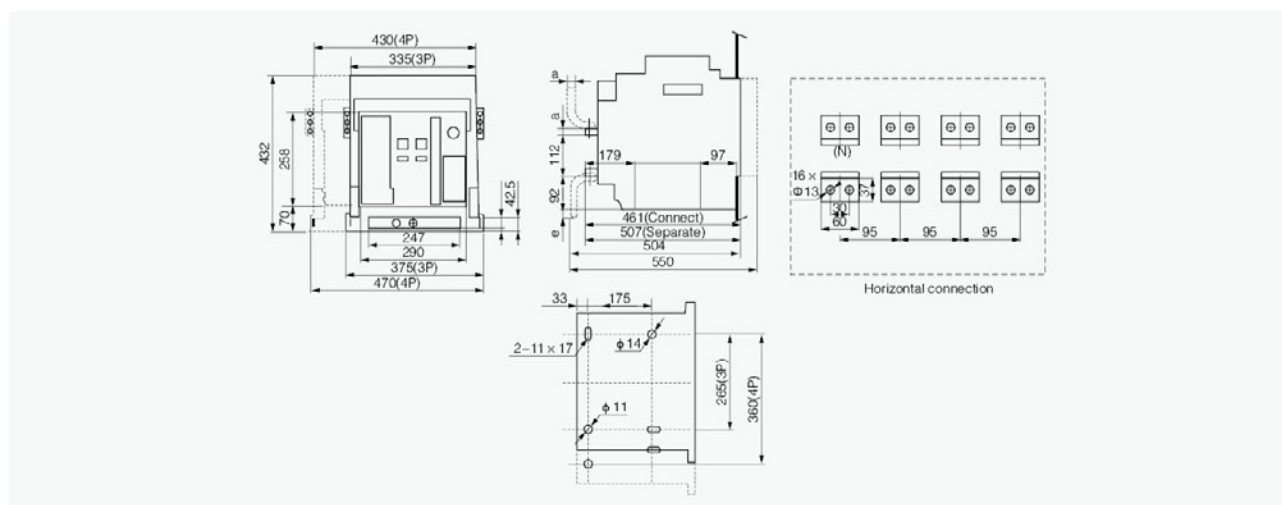

In	a	b	e
400-800A	10	37	3
1000-1600A	15	37	13
2000A	20	37	23

RDW1(DW45) Series^v

Overall And Mounting Dimensions (mm)

- Draw-out circuit breaker mounting and overall dimensions (RDW1-3200)

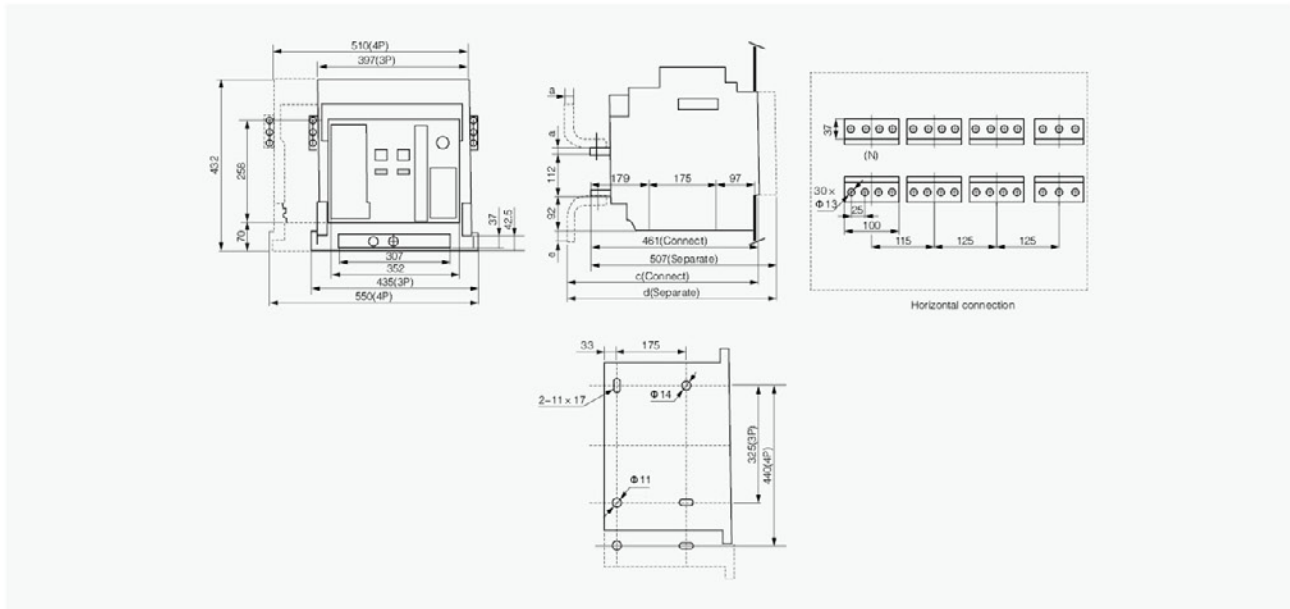

In	a	b	c	d	e
2000A, 2500A	20	37	506	552	23
2900A, 3200A	30	37	526	572	43

- Draw-out circuit breaker mounting and overall dimensions (RDW1-4000, 5000/3Poles)

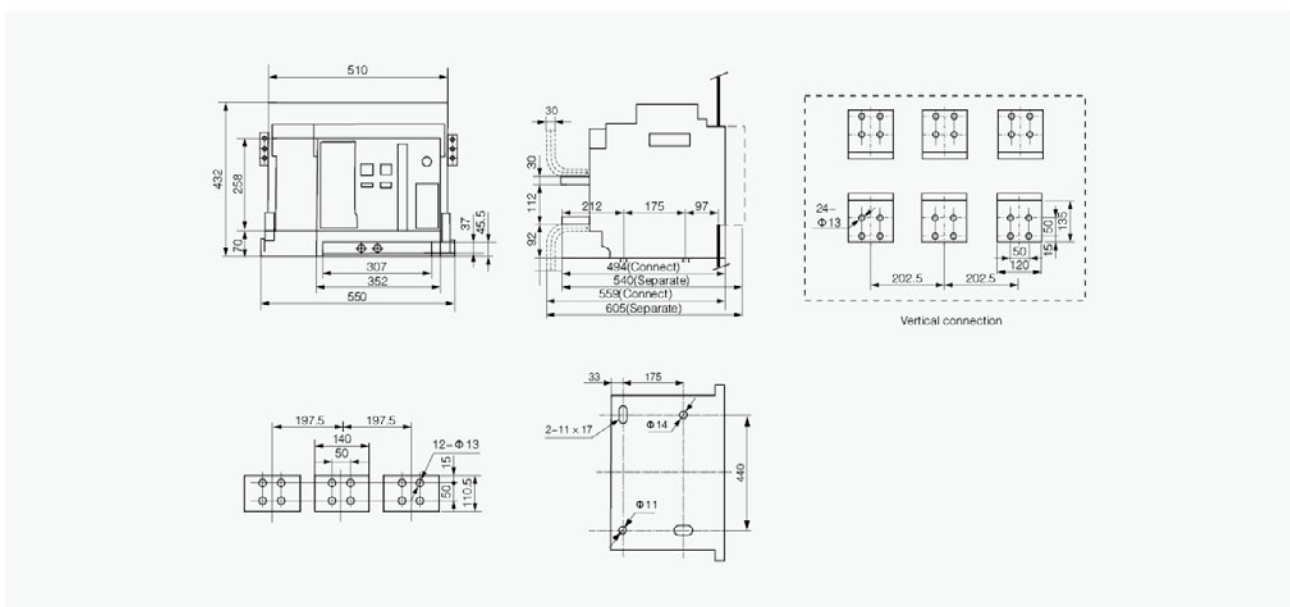

RDW1(DW45) Seriesv

Overall And Mounting Dimensions (mm)

- Draw-out circuit breaker mounting and overall dimensions (RDW1-6300 In=6300A)

Note: From panel center to circuit breaker center is 246.5

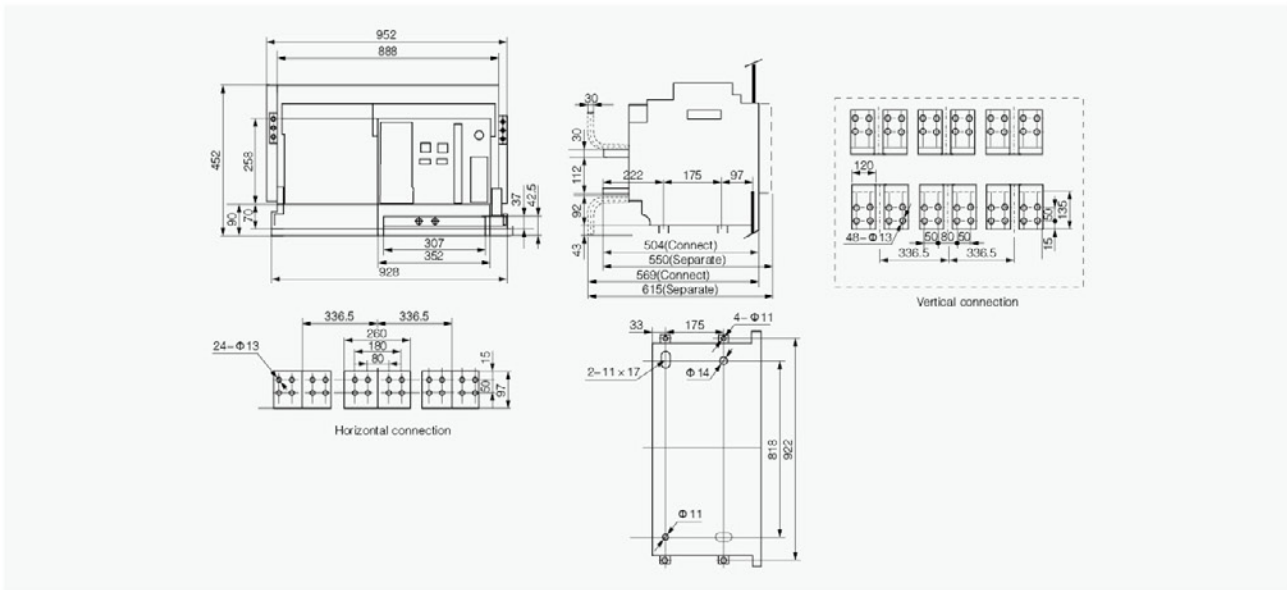

- Draw-out circuit breaker mounting and overall dimensions (RDW1-6300/4 In=6300A)

Note: From panel center to circuit breaker center is 304

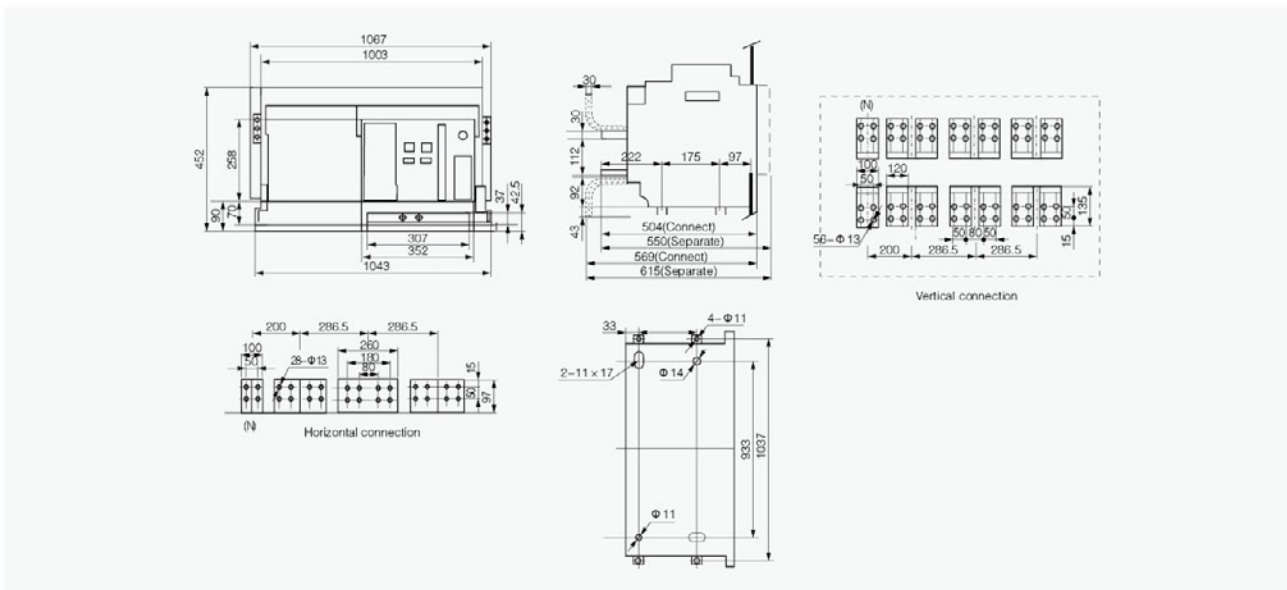

Intelligent Frame Type Universal Breaker

RDW1(DW45) Seriesv

Busbar specifications table					
rated current	busbar specification	number of busbar	rated current	busbar specification	number of busbar
630A	40×5	2	2900A	100×10	3
800A	50×5	2	3200A	120×10	3
1000A	60×5	2	3600A	120×10	4
1250A	80×5	2	4000A	120×10	4
1600A	100×5	2	5000A	120×10	5
2000A	100×5	3	6300A	120×10	6
2500A	100×5	4			

Panel Size And Installation Hole Spacing(mm)

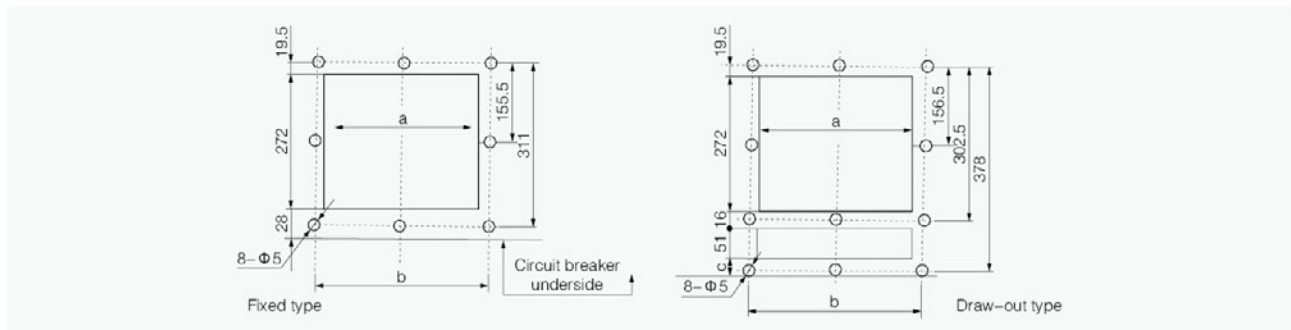

In	a	b	c
2000	306	345	0
3200, 4000/3	366	405	0
4000/4	306	345	20
6300	366	405	20

M Type Controller

- ① reset key
- ② current (voltage), time indicator
- ③ select key
- ④ LED indicator
- ⑤ clear LED key. After the setting, testing and fault checking of the controller, make the circuit breaker at normal operation.
- ⑥ setting key
- ⑦ fault checking key. After the breaker tripping, press this key to indicate the kind of fault.
- ⑧ Tripping and Non-tripping key
- ⑨ storage "+" "-" key

Is short time-delay current setting value

Ts short time-delay time setting value

Ii short circuit instantaneous current setting value

Ig earthing current setting value

Tg earthing time setting value

Ir long time-delay current setting value

Tr long time-delay time setting value

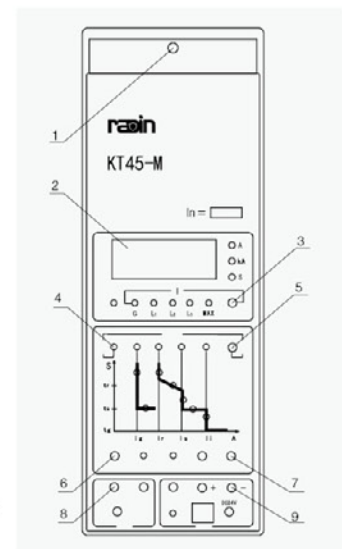

RDW1(DW45) Seriesv

L Type Controller

- ① Reset key
After the breaker tripping, press it to switch the breaker.
- ② Unload indicator
Indicate overload long time-delay current
- ③ Long time-delay, short time-delay, instantaneous and earthing protective current setting key
- ④ Fault indicator key
Indicate the kind of fault
- ⑤ Clear LED key
After the setting, testing and fault checking of the controller, make the circuit breaker at normal operation.
- ⑥ Long time-delay overload time setting key
- ⑦ Earthing current setting key
- ⑧ Short time-delay time setting key
- ⑨ Fault checking key
After the breaker tripping, press it to indicate the kind of fault
- ⑩ Select key
- ⑪ Test key

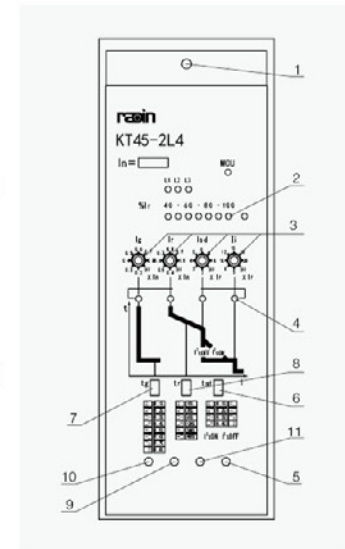

L Type Setting

- Long time-delay setting
I_r setting current from (0.4-1)I_n;
T_r setting time is 30s, 60s, 120s and 240s
Rotate I_r to off position to quit the function
- short time-delay setting
I_{sd} setting current from (3-10)I_n;
T_{sd} setting time is 0.2s and 0.4s.
Rotate I_{sd} to off position to quit the function
- Instantaneous setting
I_i setting current from (3-10)I_n or (10-20)I_n or (7-14)I_n;
Rotate I_i to off position to quit the function
- earthing fault setting
I_g setting current from (0.2-0.8)I_n
T_g setting time is 0.2s, 0.4s, 0.6s and 0.8s
Rotate I_g to off position to quit the function
- Controller is in operation state.
Press clear LED key to finish all the parameters.